

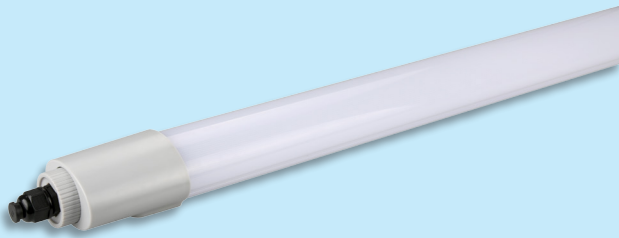

Technical Application
Guide for Benluxon
LED Batten Light

BTR03-13-40W

Introduction



Benluxon BTR03 is a high quality LED batten with high luminous efficacy 115lm/w. With a reliable and robust housing structure (IK10 & IP66), this maximizes the endurance and contributes to its long lifetime. With its flexible installation accessories, it can be used in a wide variety of applications. Three size in length (700mm 1300mm 1600mm), and various lumens package, let it to be ideal replacement for traditional fluorescent batten.

Features

1. LED batten light IP66, compact design and suitable for both indoor and outdoor applications.
2. Input voltage: 100Vac -277Vac, suitable for all the markets.
3. Elegant outlook with rearwards-directed light to illuminate the ceiling.
5. Colour rendering index (CRI): $R_a > 80$
6. Impact protection: IK10
7. LED service life: approx. 50,000 hours @L80/B10 25°C.
8. End caps: made of shockproof polycarbonate (PC).
9. Extruded PC opal diffuser with inner prisms and UV resistant, providing homogenous light distribution.
10. Flexible installation through sliding mounting bracket. Ideal for luminaire replacement.
11. Providing through-wiring for further luminaires (safety class II) connection.
12. Tool free mains cable installation on both sides through twist lock fastener cover at both sides.

Application notes

- IP66 for indoor and outdoor use
- The lamp must be installed by professional electrician
- Ensure the power supply is switched off before fitting this product
- Do not touch the lamp when in use
- Keep away from hot steam and corrosive gas

Applications

Car parks, warehouses, workshops, underground areas.

Certificate

CE **RoHS** **SAA**

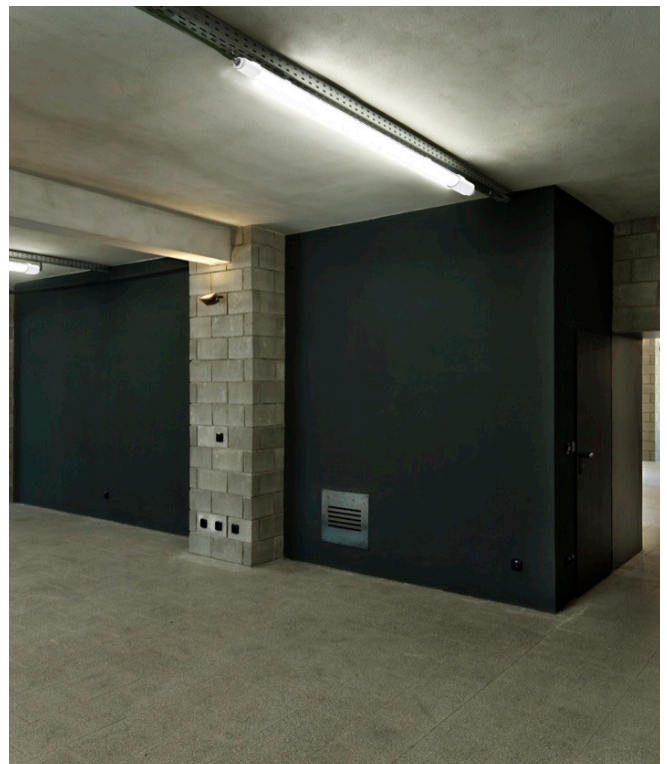

Product Information

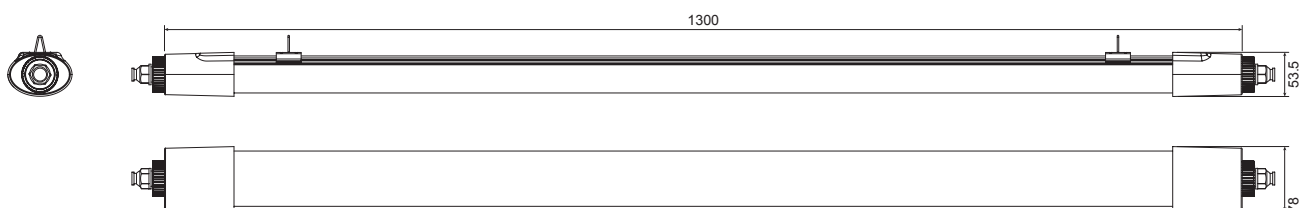

Technical Specifications

Model	Voltage	Power	Power Factor	Lumen (±5%)	Beam angle	CCT	Lifespan	CRI	Dimmable	Dimension
BTR03-13-40W	AC100-277V	40W	≥0.9	4200	140°	3000K	50000h	≥80	No	1300*78*53.5mm
BTR03-13-40N	AC100-277V	40W	≥0.9	4640	140°	4000K	50000h	≥80	No	1300*78*53.5mm
BTR03-13-40P	AC100-277V	40W	≥0.9	4680	140°	5000K	50000h	≥80	No	1300*78*53.5mm
BTR03-13-40C	AC100-277V	40W	≥0.9	4560	140°	5700K	50000h	≥80	No	1300*78*53.5mm

Driver data Sheet

Driver data	Main Power
Input rated Voltage	AC100-277V
Frequency	50/60Hz
Input Voltage	AC90-305V
Efficiency	≥86%
Total load Wattage	40W±5%
Power Factor	≥0.9
Rated input current	≤0.45A
Full load output Voltage	DC65-75V
Rated output current	260mA*2
Output current range	(260mA*2)±5%
Power tolerance	±5%
Current output tolerance	±5%
Short circuit protection	PASS
Over voltage protection	PASS
Over temperature protection	PASS
THD	≤20%
Withstand voltage	—

Fixture Compatibility

Rated Wattage	Electrical Classification	Ingress Protection	Operating Temp	Operating Humidity	Storage Temp
40W	II	IP66	-20°C~45°C	0~90%	-20°C~65°C

Spectral Distribution

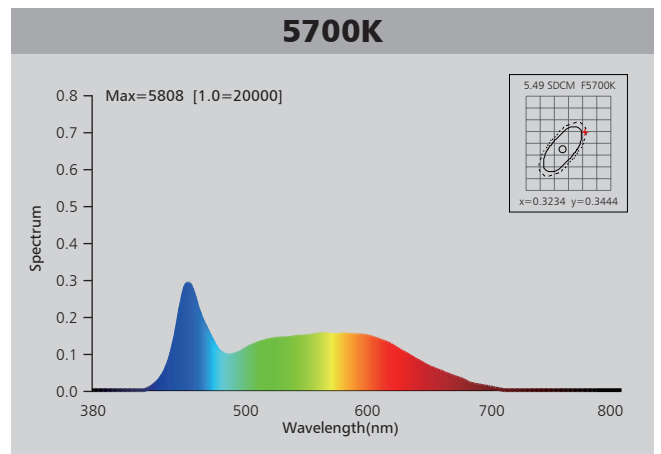
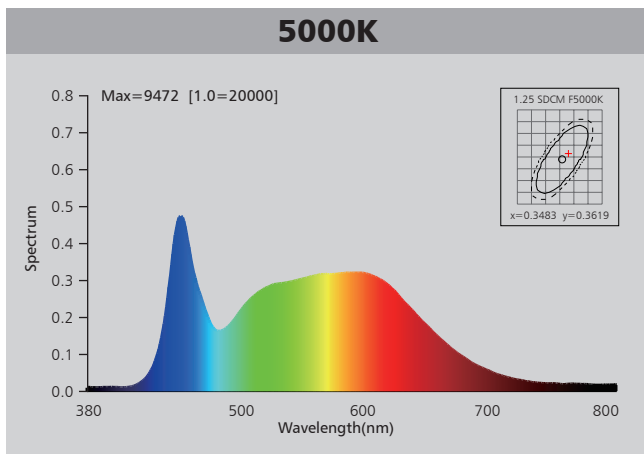
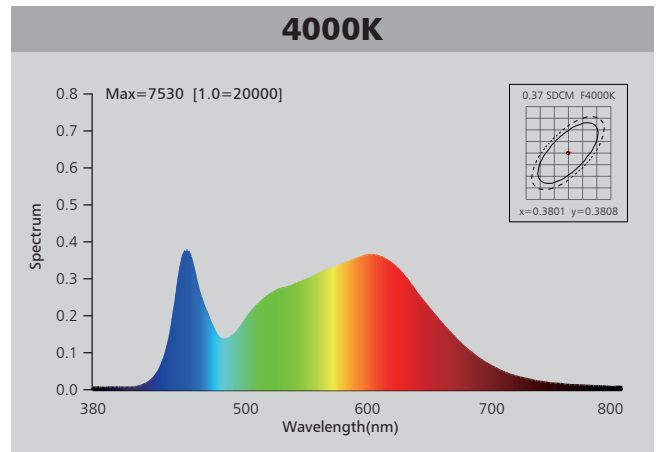
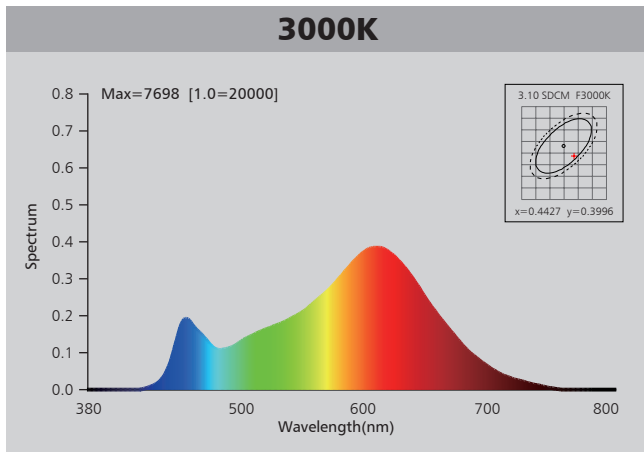

Photometric Diagram

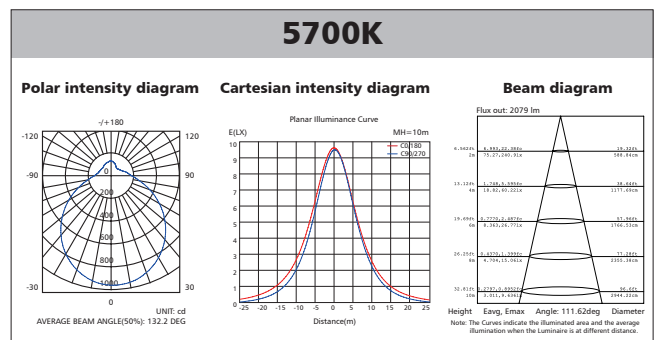
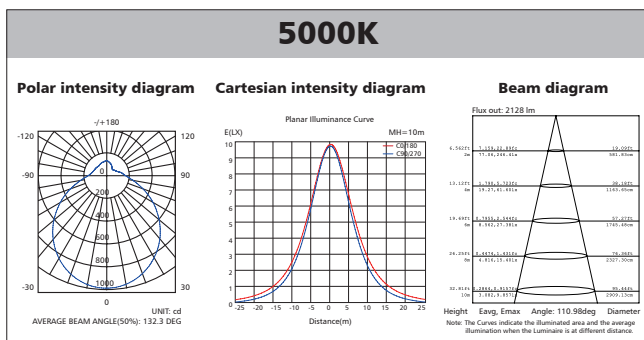
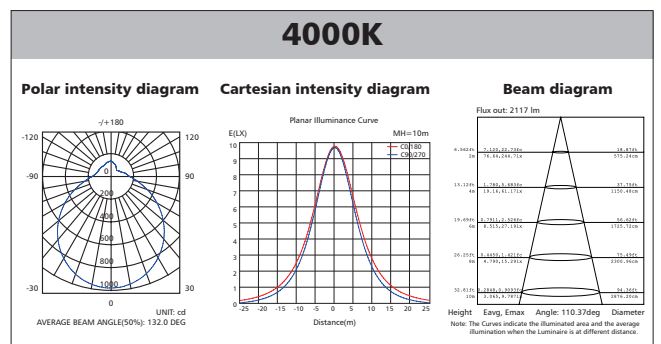
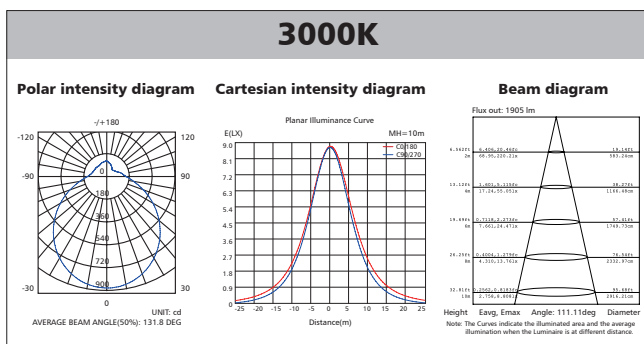

Polar Diagram Comparison

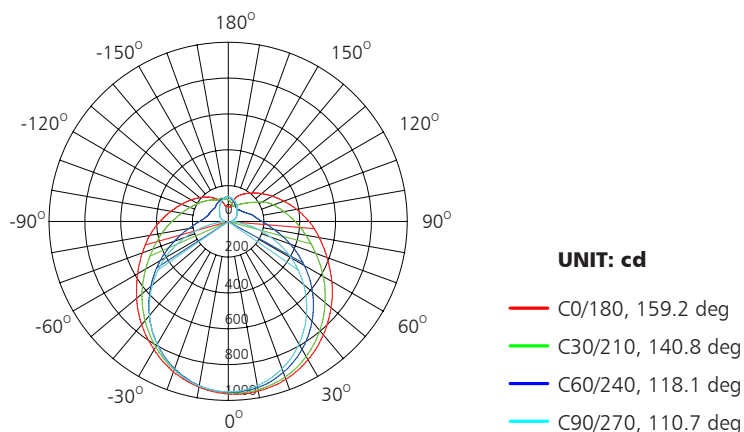

AVERAGE BEAM ANGLE (50%): 132.2DEG



Driver lifetime & LED light decay rate

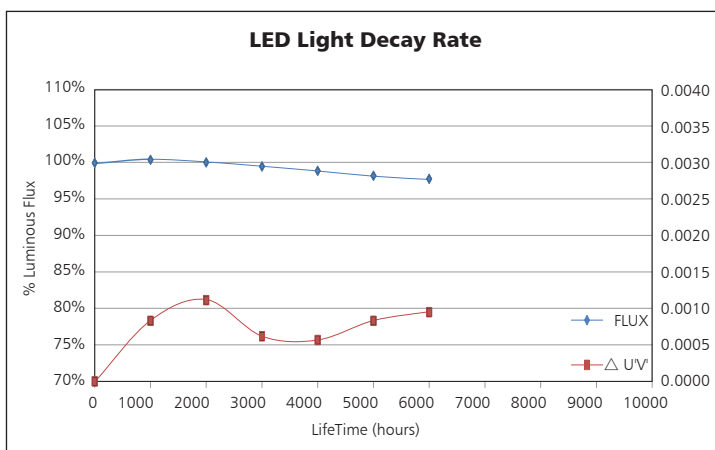
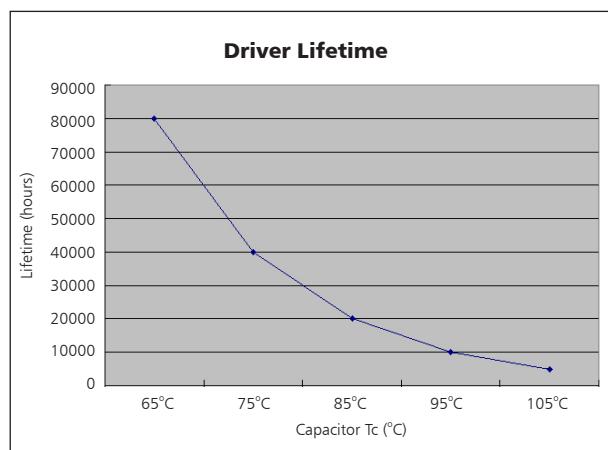

Temperature

- The testing is operated at 25°C
- The lifetime of capacitor, minimum of 5,000 hours if operated at 105°C, will be doubled whenever the temperature drops 10°C
- The highest withstand temperature of IC, MOS could be 120°C
- The highest withstand temperature of LED junction temperature is 150°C

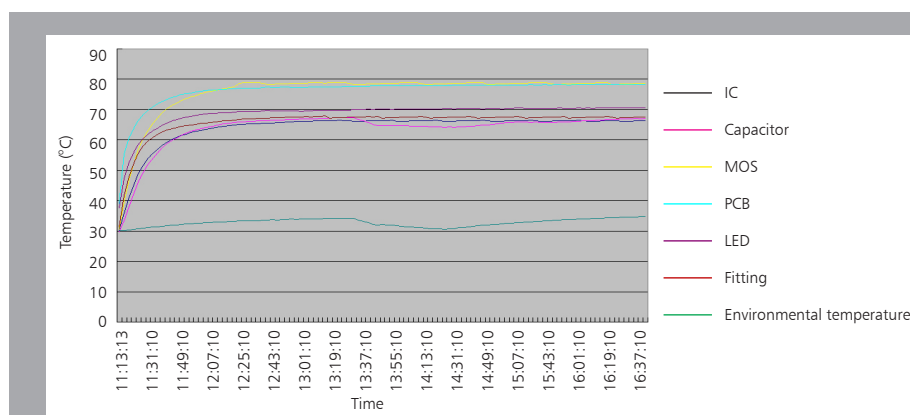

The driver lifespan is based on capacitor working temperature.



ART-NR	Linkable luminaries Qty	
	100-130V	200-277V
BTR03-13-40W	12	26

Installation 1

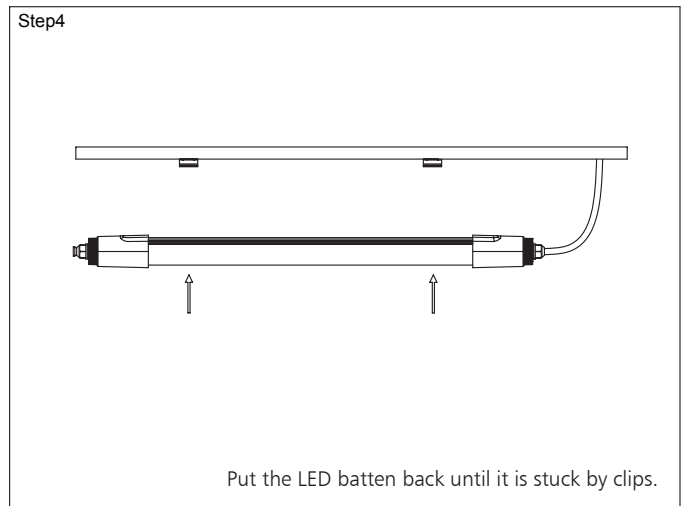
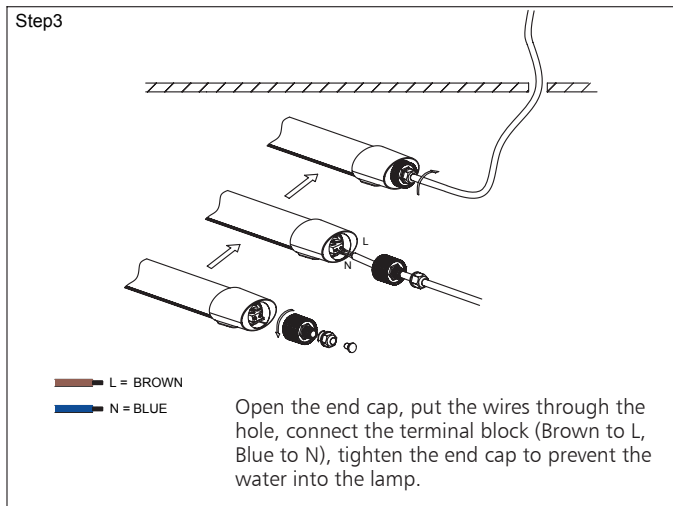
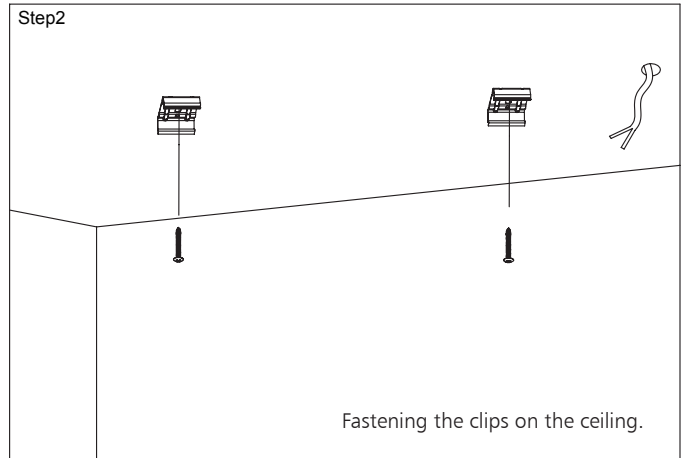
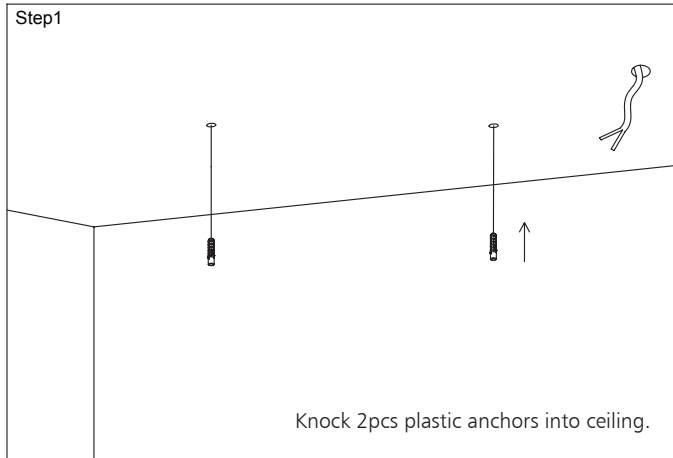

Installation 2

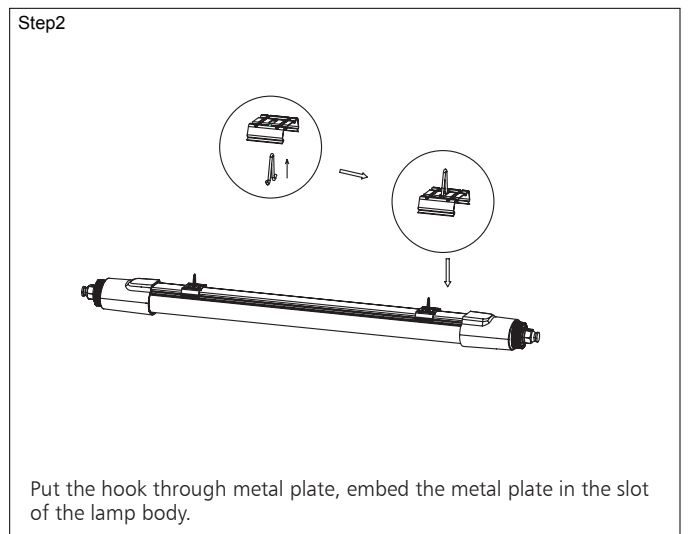
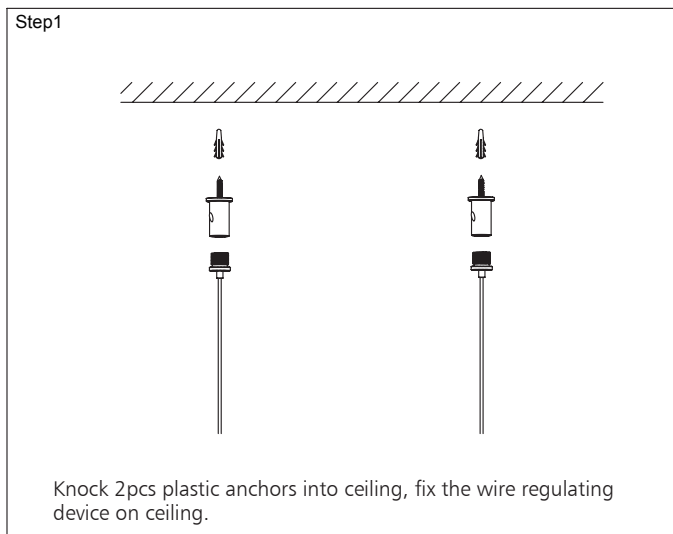

Step3

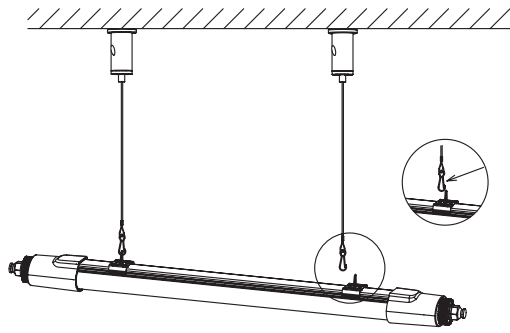

Hanging the lamp to the suspending wires.

Step4

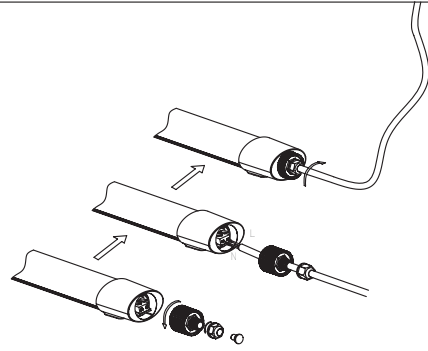

— L = BROWN
— N = BLUE

Open the end cap, put the wires through the hole, connect the terminal block (Brown to L, Blue to N), tighten the end cap to prevent the water into the lamp.

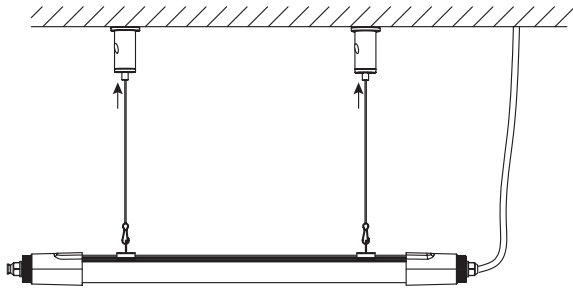

Adjust the length of suspending wires on same level, turn on the light.

Packaging Information

	SIZE(CM)	N.W/pc (KGS)	G.W.(KGS)	QTY(PCS)
Carton	151.5*29.5*19.5	0.8	8	8

	CTNS	QTY(PCS)	VOLUME(CBM)
20" standard container	316	2528	28
40" standard container	634	5072	56

